

(12) PATENT	(11) Application No. AU 199523306 B2	
(19) AUSTRALIAN PATENT OFFICE	(10) Patent No. 715517	
(54) Title Structural bracing for buildings		
(51)⁶ International Patent Classification(s) E04B 002/56 E04C 003/02		
(21) Application No: 199523306	(22) Application Date: 1995.06.28	
(30) Priority Data		
(31) Number PM6487	(32) Date 1994.06.28	(33) Country AU
(43) Publication Date : 1996.01.11		
(43) Publication Journal Date : 1996.01.11		
(44) Accepted Journal Date : 2000.02.03		
(71) Applicant(s) Marojoed Pty Ltd		
(72) Inventor(s) Paul Polikapo Tonglatama		
(74) Agent/Attorney Marojoed Pty Ltd, PO Box 5117, Alexandra Hills, Queensland 4161		
(56) Related Art AU 15051/83 US 5729950		

AUSTRALIA

Patents Act 1990

**ORIGINAL
COMPLETE SPECIFICATION
STANDARD PATENT**

Invention Title: "STRUCTURAL BRACING FOR BUILDINGS"

2
3
4
5
6
7
8
9
10
11
12
13
14
15
16
17
18
19
20
21
22
23
24
25
26
27
28
29
30
31
32
33
34
35
36
37
38
39
40
41
42
43
44
45
46
47
48
49
50
51
52
53
54
55
56
57
58
59
60
61
62
63
64
65
66
67
68
69
70
71
72
73
74
75
76
77
78
79
80
81
82
83
84
85
86
87
88
89
90
91
92
93
94
95
96
97
98
99
100

The following statement is a full description of this invention, including the best method of performing it known to us:



THIS INVENTION relates to structural bracing for buildings.

The invention is particularly suitable for, but not limited to, the structural bracing of timber- or steel-framed walls.

The various State building codes specify the minimum allowable standards for bracing. For example, in Queensland, buildings on the Sunshine Coast and further north must be able to withstand certain cyclonic winds; while in the far north of Queensland, eg. Townsville and above, the buildings must be able to withstand cyclonic winds of higher intensity.

Any bracing for building walls must satisfy a number of criteria, including:

- (1) ease of installation;
- (2) low cost; and
- (3) the ability to provide the bracing as set out in the relevant codes.

One example of the bracing for timber frame walls is disclosed in AU-B-47013/79 (534742) (TURNER) where an L-shaped metal strip has one flange received in aligned slots cut in the studs and a second flange secured, eg. bolts, screws, nails, to the exposed faces of the studs.

In an alternative form of bracing, plywood panels are fixed, eg. to two or three adjacent studs to brace the wall in the plane of the wall.

With the first bracing method, carpenters find it annoying to have to cut the slots in the studs to install the L-shaped bracing; and the cuts reduce the structural strength of the studs. With the second method, plywood panels can make it difficult to install internal or external cladding to the walls as the thickness of the plywood panels must be accommodated for.

It is an object of the present invention to provide a bracing assembly which is particularly suitable for, but not limited to, providing structural bracing for walls for buildings in cyclonic areas.

5 It is a preferred object of the present invention to provide a bracing assembly which is pre-assembled at the factory and which can be easily installed.

It is a further preferred object of the present invention to provide a bracing assembly which has a high structural strength in the longitudinal plane of the wall.

10 Other preferred objects of the present invention will become apparent from the following description.

In one aspect, the present invention resides in a truss-like brace assembly for a building wall of the type having a top wall plate and a bottom plate interconnected by a plurality of spaced vertical studs, the bracing assembly including:

15 a peripheral frame having a pair of substantially vertical stiles interconnected by a top member and a bottom member; and

at least one diagonal brace connected to the stiles to triangulate the peripheral frame;

20 the stiles being fixed to respective studs in an adjacent pair of the studs in the wall to provide structural bracing to the wall in a longitudinal plane thereof.

25 Preferably, the top member and bottom member are respectively fixed to the top wall plate and the bottom plate in the wall.

Preferably, the peripheral frame is substantially rectangular in front view and is dimensioned to be a close fit in a rectangular cavity in the wall defined by the studs, top wall plate and bottom plate.



Preferably, at least one substantially horizontal cross-brace interconnects the stiles, and at least one of the diagonal braces bisects the or each rectangular space in the peripheral frame defined by the stiles and an adjacent pair of the horizontal cross-braces.

5 Preferably, the diagonal braces are alternatively inclined in the peripheral frame, where each end of each diagonal brace is fixed to one of the stiles at a junction between the one stile and one of the cross-braces.

10 Preferably, the stiles, top member, bottom member, and diagonal brace(s) are of C-, L-, RHS- or SHS-metal section.

Preferably, the cross brace(s) are also of C-, L-, RHS- or SHS-metal section.

In a second aspect, the present invention resides in a wall structure for a building including:

15 a plurality of studs, interconnecting a top wall plate and a bottom wall plate; and a brace assembly as hereinbefore described wherein:

the stiles are fixed to the studs; and

20 the brace provides structural bracing for the wall in a longitudinal plane thereof.

Preferably, the peripheral frame is a close fit in a cavity, in the wall structure, defined by the studs, top wall and bottom plate;

the stiles are fixed to the studs;

25 the top member is fixed to the top wall plate; and

the bottom member is fixed to the bottom plate.

To enable the invention to be fully understood, preferred embodiments will now be described



with reference to the accompanying drawings, in which:

FIG 1 is an isometric view of a portion of a building wall provided with a bracing assembly of a first embodiment of the invention; and

5 FIG 2 is a similar view showing a second embodiment of the present invention.

Referring to FIG 1, the wall structure 10 has vertical studs 11 interconnected by a top wall plate 12 and a bottom plate 13.

10 A brace assembly 20, in accordance with a first embodiment of the invention, is fitted within the rectangular space defined by the studs 11, top wall plate 12, and bottom plate 13.

15 The brace assembly 20 has a pair of vertical stiles 21, 22 interconnected by a top member 23 and a bottom member 24.

Four substantially horizontal cross-braces 25 interconnect the stiles 21, 22 and the resultant substantially rectangular spaces defined by the stiles 21, 22 and the cross-braces 25 (and top member 23 and bottom member 24) are bisected by diagonal braces 26 which are alternately inclined above the height of the brace assembly 20. It will be noted that for the intermediate diagonal braces 26, each end of the diagonal brace 26 is connected to a stile 21, 22 at the junction of the stile 21, 22 with one of the cross-braces 25.

25 The stiles 21, 22, the top member 23, the bottom member 24, the cross-braces 25, and the diagonal braces 26, are formed of C-section cold-rolled steel, which may be galvanised, power-coated or otherwise corrosion-proofed.

30 The components of the brace 20 may be welded, screwed or riveted together, and the triangulation of 35 the brace assembly 20 by the diagonal braces 20 (in

conjunction with the cross-braces 25) provides a rigid, strong, light-weight, truss-like assembly to brace the wall 10. The brace assembly 20 is fixed to the wall structure 11 by fasteners 30 (eg. nails, screws, self-tapping screws), driven through the web portions of the stiles 21, 22, top member 23 and bottom member 24 into the adjacent studs 11, top wall plate 12 and bottom plate 13.

It will be readily apparent to the skilled addressee that the brace assembly 20 provides good structural bracing against racking loads applied to the wall structure 11 in the plane of the wall structure.

Referring to FIG 2, the wall structure 110 has studs 111, top wall plate 12 and bottom plate 13 formed from metal sections. The brace assembly 120 has a configuration substantially as hereinbefore described with reference to the brace assembly 20 except that the stiles 121, 122, top member 123, bottom member 124, cross-braces 125 and diagonal braces 126 are of square, hollow section (SHS) steel. The installation and the operation of the brace assembly 120 is as hereinbefore described.

Preferably, the brace assemblies 20, 120 are manufactured in tethered heights (eg. to suit 2400mm or 2700mm stud walls) and of standard widths, eg. to suit 450mm and 600mm stud spacings.

In the embodiments shown, the bottom members 24, 124 have been described as being fixed to a bottom plate. It will be readily apparent to the skilled addressee that the bottom members could be fixed directly to a concrete slab floor.

For buildings in areas where higher cyclonic loads are encountered, the external dimensions of the components, and the wall thicknesses thereof, may be increased to provide greater structural strength.

As the brace assemblies 20, 120, can be manufactured in a factory to close tolerances, they avoid on-site assembly of the bracing and enable the bracing to be easily installed and fixed in the wall structures.

Various changes and modifications may be made to the embodiments described and illustrated without departing from the present invention.



The claims defining the invention are as follows:

1. A truss-like brace assembly for a building wall of the type having a top wall plate and a bottom plate interconnected by a plurality of spaced vertical studs, the brace assembly including:
- 5 a peripheral frame having a pair of substantially vertical stiles interconnected by a top member and a bottom member; and at least one diagonal brace connected to the stiles to triangulate the peripheral frame;
- the stiles being fixed to the respective studs in an adjacent pair of the studs in the wall to provide structural bracing to the wall in a longitudinal plane thereof.
- 10 2. A brace assembly according to Claim 1 wherein: the top member and bottom member are respectively fixed to the top wall plate and the bottom plate in the wall.
- 15 3. A brace assembly according to Claim 2 wherein: the peripheral frame is substantially rectangular in front view and is dimensioned to be a close fit in a rectangular cavity in the wall defined by the studs, top wall plate and bottom plate.
- 20 4. A brace assembly according to any one of Claims 1 to 3 wherein: at least one substantially horizontal cross-brace interconnects the stiles and at least one of the diagonal braces an or each rectangular space in the peripheral frame defined by the stiles and an adjacent pair of the horizontal cross-braces.
- 25 5. A brace assembly according to Claim 4 wherein: the diagonal braces are alternatively inclined in the peripheral frame, where each end of each diagonal brace is fixed to a respective one of the stiles at a junction between the one stile and one of the cross-braces.
- 30 6. A brace assembly as claimed in any one of Claims 1 to 5



wherein:

the stiles, top member, bottom member, and diagonal
brace(s) are of C-, L-, RHS- or SHS- metal section.

7. A brace assembly as claimed in Claim 4 or Claim 5

5 wherein:

the cross brace(s) are of C-, L-, RHS- or SHS-metal
section.

8. A wall structure for a building including:

10 a plurality of studs, interconnecting a top wall plate and
a bottom wall plate;

and a brace assembly as claimed in any one of Claims 1
to 7 wherein:

the stiles are fixed to the studs; and

15 the brace assembly provides structural bracing for the
wall in a longitudinal plane thereof.

9. A wall structure as claimed in Claim 8 wherein:

the peripheral frame is a close fit in a cavity, in the wall
structure, defined by the studs, top wall plate and bottom plate;

the stiles are fixed to the studs;

20 the top member is fixed to the top wall plate; and

the bottom member is fixed to the bottom plate.

10. A truss-like brace assembly, as claimed in Claim 1,
substantially as hereinbefore described with reference to FIG. 1; or
FIG. 2, of the drawings.

25

DATED this tenth day of November 1999.

MAROJOED PTY LTD

By its Patent Attorneys

FISHER ADAMS KELLY



ABSTRACT

A truss-like brace assembly (20, 120) for a wall (10, 110) of a building has a peripheral frame defined by a pair of stiles (21, 22, 121, 122), a top member (23, 123) and a bottom member (24, 1211), where
5 diagonal braces (25, 125) and horizontal cross-braces (26, 126) triangulate the frame. The brace assembly (20, 120) is a close fit in a cavity in the wall (10, 110) and the stiles (21, 22, 121, 122), top member (23,
10 123) and bottom member (24, 124) are fixed to the adjacent studs (11, 111), top wall plate (12, 112) and bottom plate (13, 113) to provide structural bracing in the longitudinal plane of the wall (10, 110).

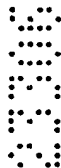

23306/95

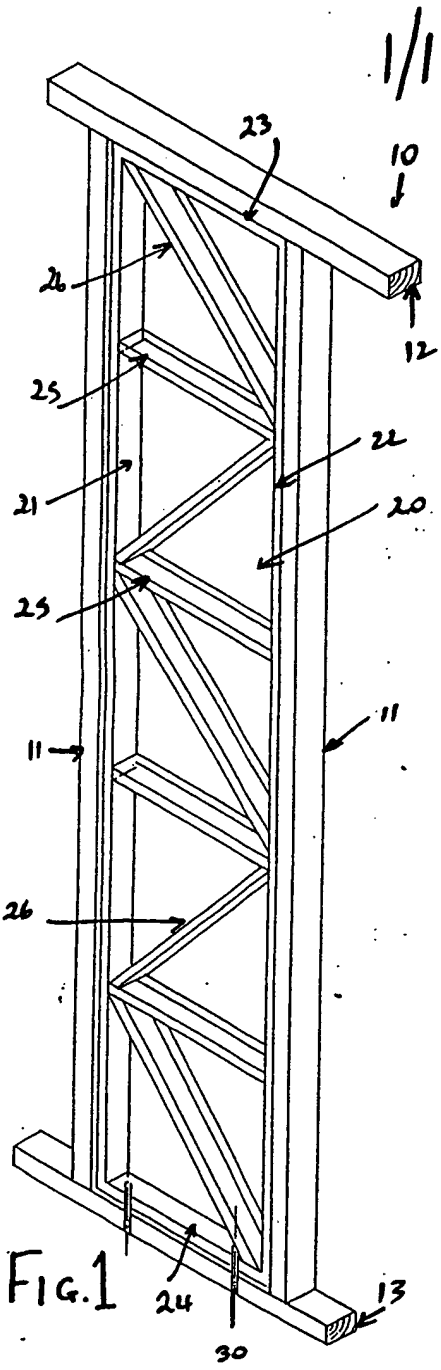

FIG. 1

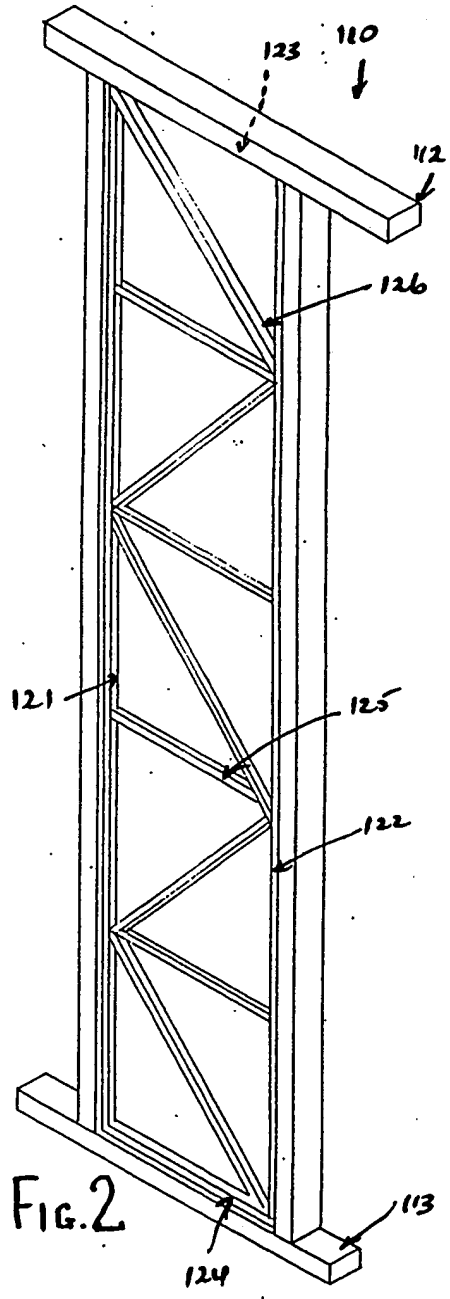

FIG. 2

